



COU End User Training



### CAMP Platform

New York City School Construction Authority								
Requirements Contracts			Hard Bid					
Mentor	JOC	Emergency						
Program	Program	Program						
Subproject	Subproject	Subproject						

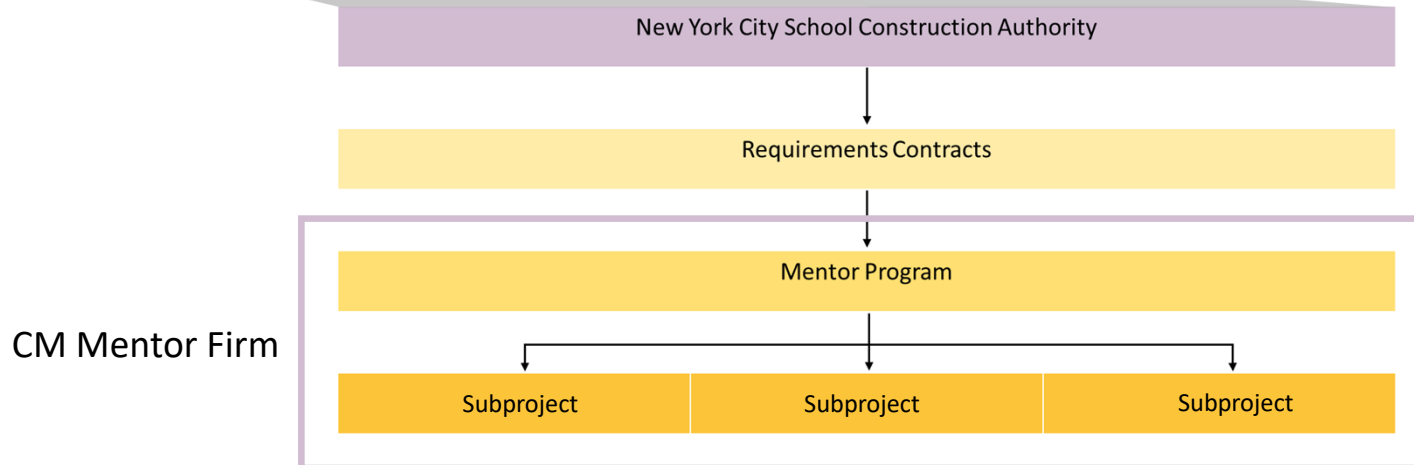

# 1. RFI

1. **CM Firm** Create New RFI
2. **CM Firm** Submit RFI for Response
3. **\*AEoR** Send RFI to Secondary Responder
4. **\*AEoR Secondary Responder** Add Secondary Response
5. **\*AEoR** Adds Secondary Response to Primary Response
6. **AEoR** Selects Closure Status (e.g., *clarification only, not valid, NOD Required, Bulletin Required*) and Responds

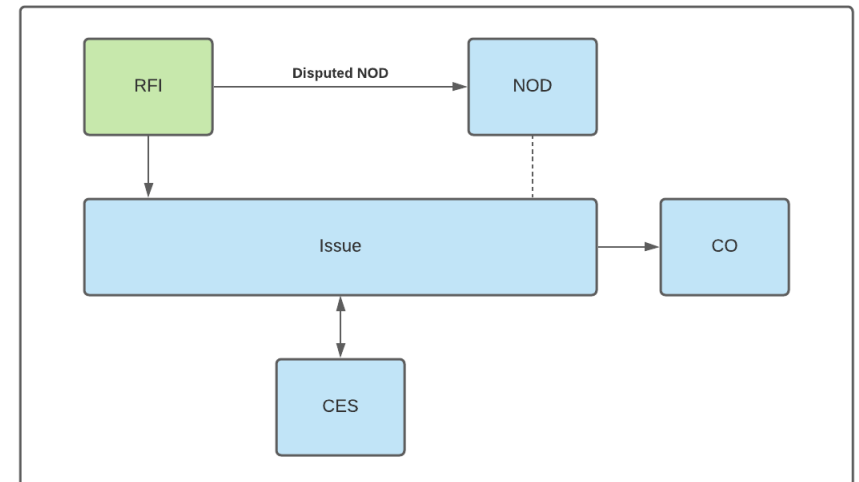
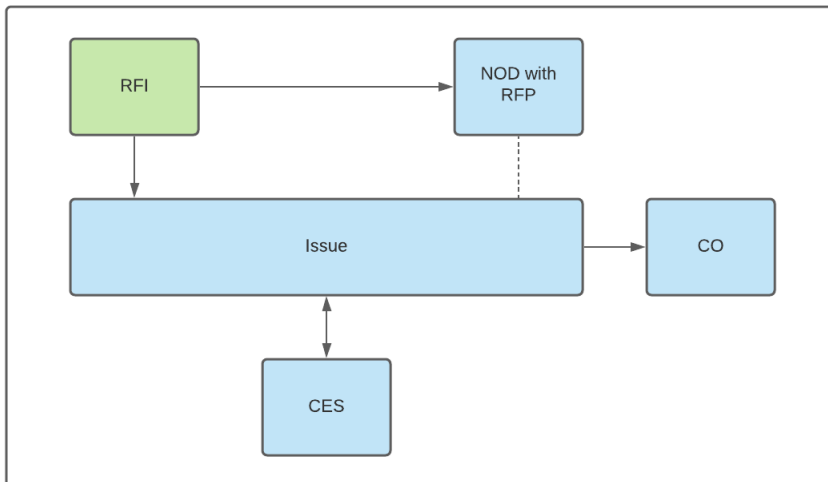
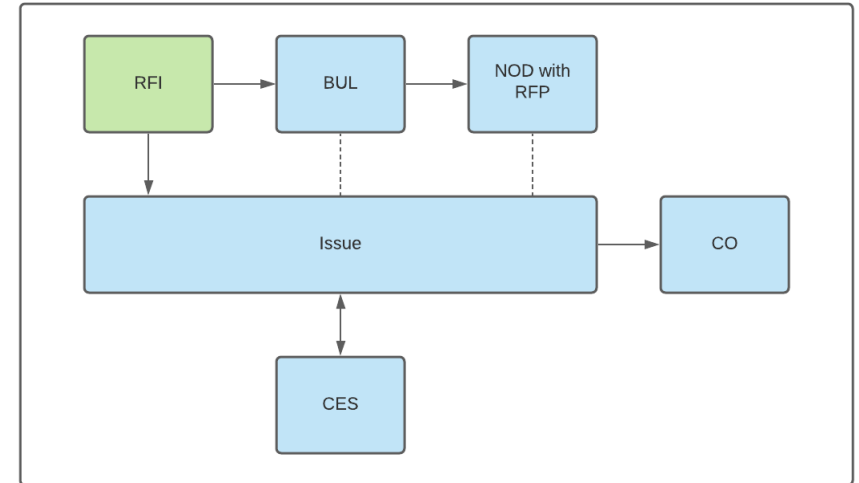

## 2. Bulletin

1. **AEoR** Initiate New Bulletin and Submit
2. **AEoR** Create an Issue (If not previously created from RFI)
3. **AEoR** Submit Bulletin
4. **Notification** to create Bulletin Estimate Shell in CES
5. **CM PM** Review to Send to GC
6. **CM Firm** Review to Accept or Return Bulletin
7. **CM PM** Meeting with All Parties of Draft BUL
8. **AEoR** Update Estimated Cost
9. **AEoR** Finalize Draft
10. **A&E DPM** reviews
11. **A&E DM** reviews and approves
12. **\*A&E Director** reviews and approves
13. **\*DCS Director** reviews and approves
14. **DCS** Notified to Review for Reason Code
15. **CM PM** Review for Completeness
16. **CM PM** Initiate NOD (Button)

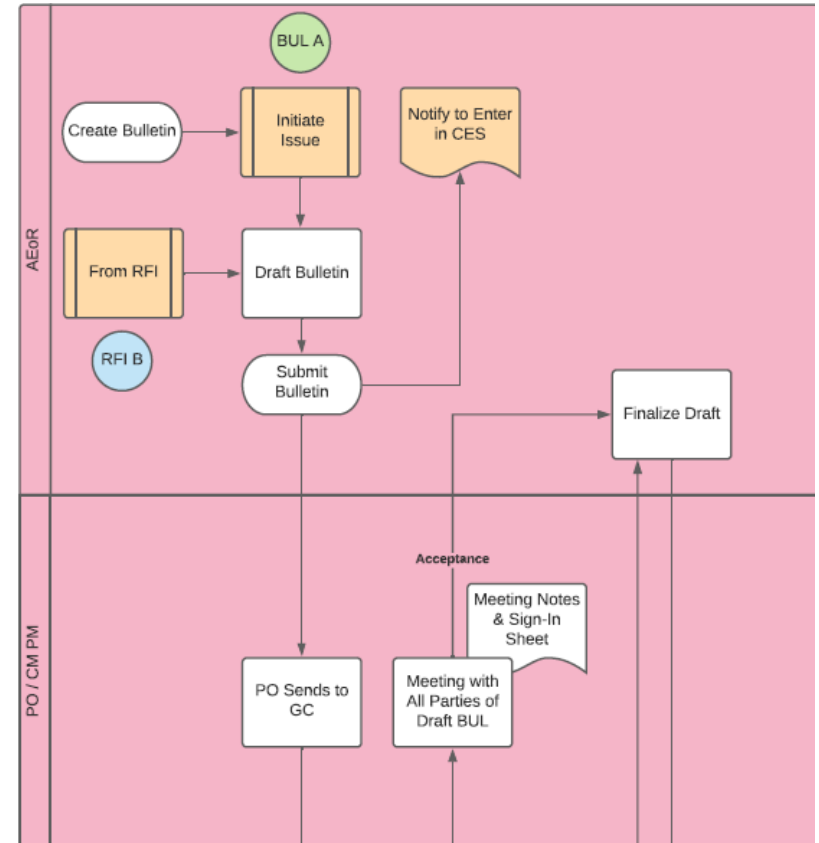

# 3. Change in Condition

- 1. **CM PM** Create new CIC
- 2. **CM PM** Initiate Issue
- 3. **CM PM** Submit CIC
- 4. **Notification** to create Estimate Shell in CES
- 5. **CM PM** Initiate NOD

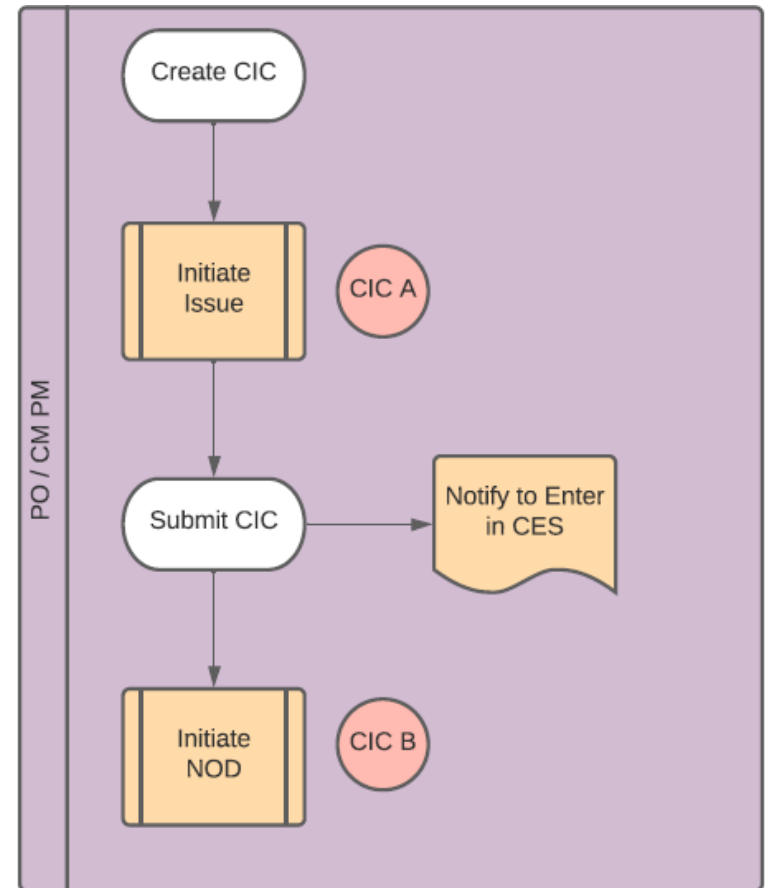

# 4. Notice of Direction

1. **External** Process from RFI/Bulletin/CIC OR Dispute NOD
2. **CM PM** Generate NOD and Submit for Approval
3. **CM PM** PIN Sign
4. **SPO** PIN Sign
5. **CPO** PIN Sign
6. **Notification** to create PCO Estimate Shell in CES
7. **Notification** to GC

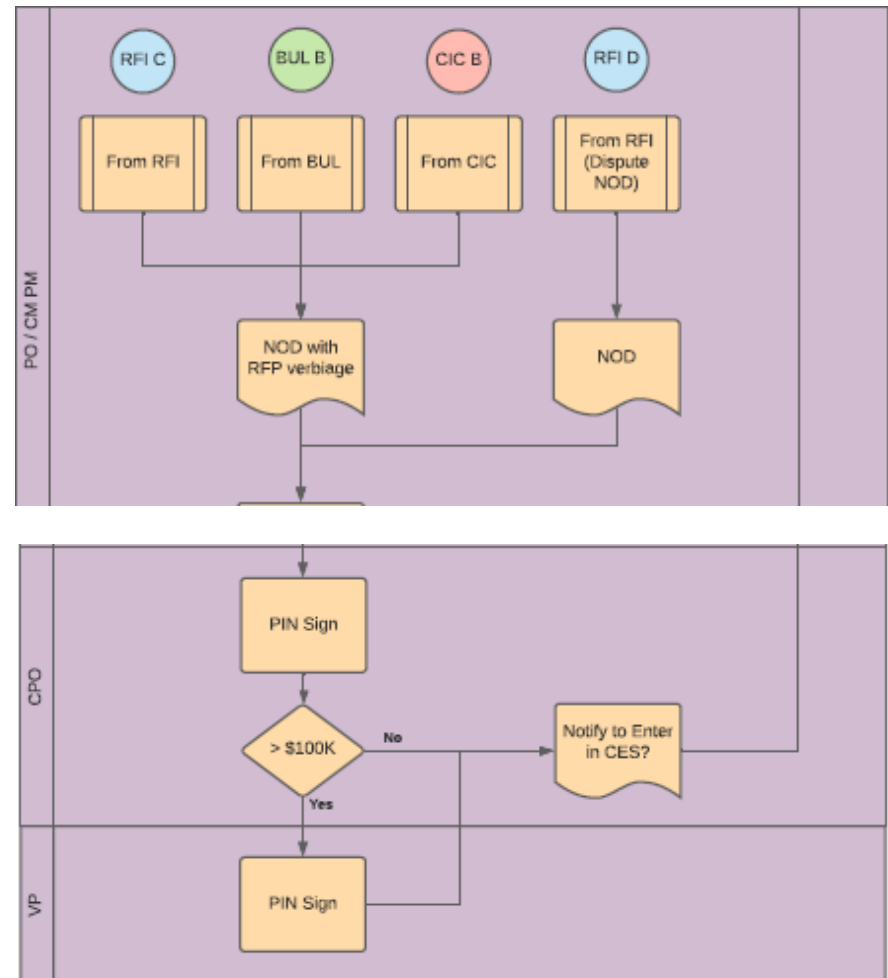

# 5. Time Change Request

1. **CM Firm** Create TCR
2. **CM Firm** Initiates Issue
3. **Notification** to create PCO Estimate Shell in CES
4. **CM Firm** Submits TCR
5. **CM PM** Accepts
6. **\*SPO** Accepts
7. **\*CPO** Accepts
8. **\*VP** Accepts
9. **Scheduling Admin.** Assign to Scheduler
10. **Scheduler** Upload Approval Doc. and Send Recommendation Memo -
11. **CM PM** send to GC
12. **GC** Approve by DocuSign
13. **CPO** Approve by DocuSign
14. **Scheduling Director** Approve by DocuSign
15. **Scheduling Admin** Package TCR
16. **COU Sr. Dir.** Complete TCR

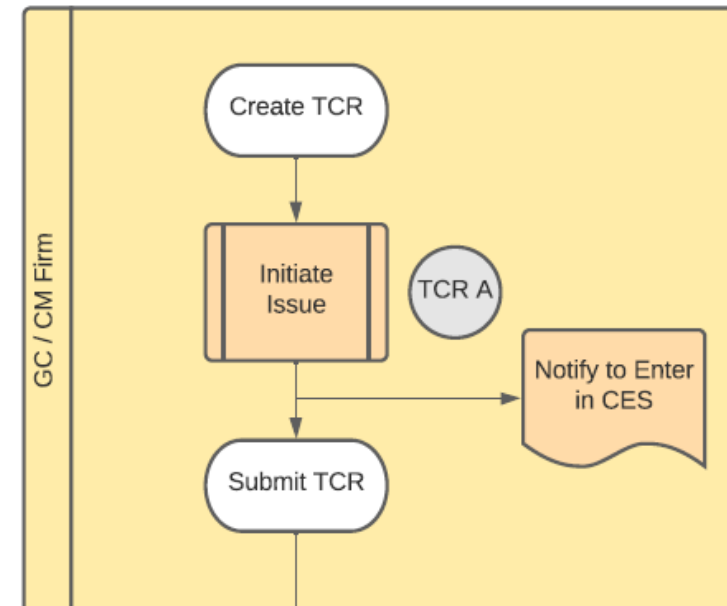

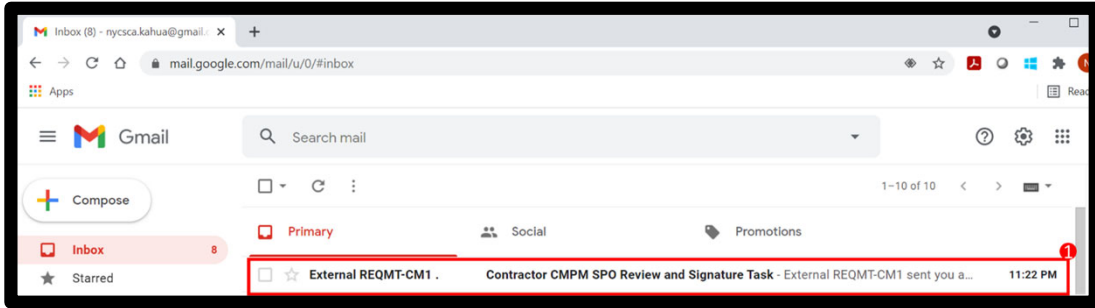





### Please Review & Act on These Documents

External REQMT-CM1  
SCA Sandbox (Development-DEVWEEKLY-6/1/2021 2:13:35 AM)

Please review the Change Order 00002 and render your decision.

Please read the Electronic Record and Signature Disclosure

I agree to use electronic records and signatures.

**CONTINUE** OTHER ACTIONS ▾

**DocuSign**

**FIELDS**

<b>FROM:</b> Deloitte	<b>TITLE:</b> Add Swings
<b>TO:</b> AJCo	<b>PROJECT:</b> C000014566-MC80004
New York, NY 12345	<b>CONTRACT NO:</b> MC00450
<b>ATTN:</b> External REQMT-CM1-PM	
<b>DESCRIPTION OF WORK</b>	
Add swings to playground	
<b>Total: \$2,500.00</b>	<b>Increase: 0 Calendar Days</b>

The Contractor agrees to perform or omit work, as described in this Change Order, for the amount and within the contract scheduled completion time period as adjusted above. In accepting and executing this

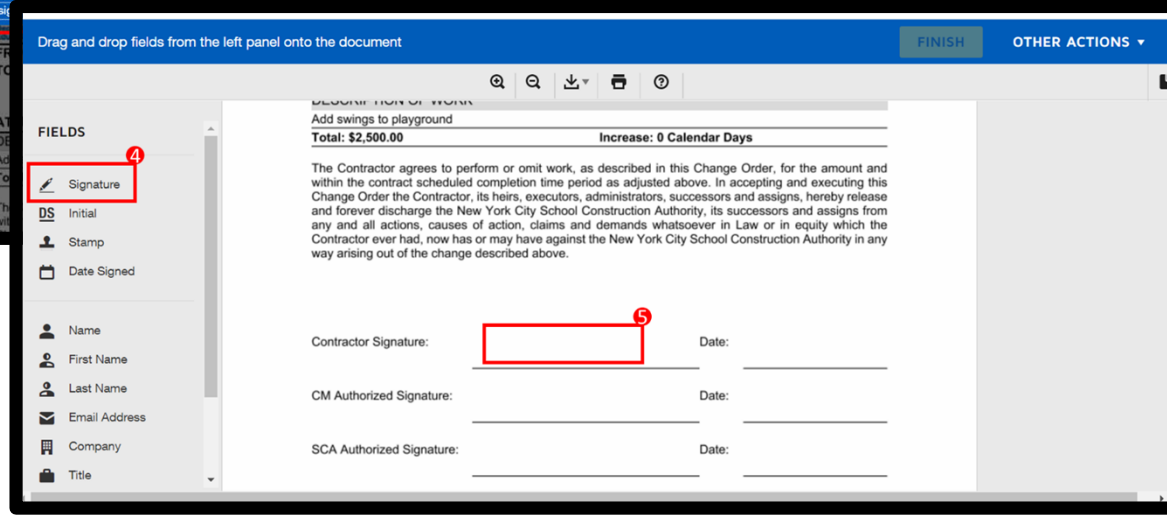
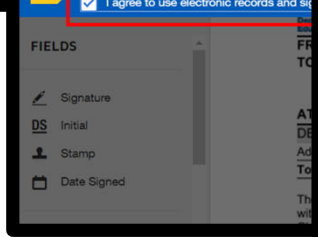



### Please Review & Act on These Documents

External REQMT-CM1  
SCA Sandbox (Development-DEWEEKLY-6/1/2021 2:13:35 AM)

Please review the Change Order 00002 and render your decision.

Please read the Electronic Record and Signature Disclosure.

I agree to use electronic records and signatures.

**CONTINUE** **OTHER ACTIONS**

#### FIELDS

- Signature
- Initial
- Stamp
- Date Signed

Drag and drop fields from the left panel onto the document

**FINISH** **OTHER ACTIONS**

DESCRIPTION OF WORK  
Add swings to playground  
**Total: \$2,500.00** Increase: 0 Calendar Days

The Contractor agrees to perform or omit work, as described in this Change Order, for the amount and within the contract scheduled completion time period as adjusted above. In accepting and executing this Change Order, the Contractor agrees to be bound by the terms and conditions of the contract and any and all amendments, addendums, and other documents incorporated by reference into the contract. The Contractor agrees to be bound by the terms and conditions of the contract and any and all amendments, addendums, and other documents incorporated by reference into the contract.

Contract  
CM Aut  
SCA Au

#### FIELDS

- Signature
- Initial
- Stamp
- Date Signed
- Name
- First Name
- Last Name
- Email Address
- Company
- Title

### Adopt Your Signature

Confirm your name, initials, and signature.

\* Required

**Full Name\***  **Initials\***

**SELECT STYLE** **DRAW** **UPLOAD**

**PREVIEW** [Change Style](#)

DocuSigned by:  
*SCA Grp Test EXT-GC-1*   
E93978DA3E2E4F8...

By selecting Adopt and Sign, I agree that the signature and initials will be the electronic representation of my signature and initials for all purposes when I (or my agent) use them on documents, including legally binding contracts - just the same as a pen-and-paper signature or initial.

**ADOPT AND SIGN** **CANCEL**

## 6. Issues

1. **CM PM** enters Estimate and PCO
2. **COU Lead Estimator** Enters FRE, CO (Only if >\$25K)
3. **COU Lead Estimator** Initiates CO

# 7. Change Order - Amendment

1. **COU Lead Est.** Initiates CO for DocuSign (*Same as last step shown in issues*)
2. **GC > CM PM** Review and DocuSign Change Order
3. **COU Lead Est.** Compile Change Order Package
4. **COU Manager** Review and Pin Code Sign
5. **COU Senior Director** Review and Pin Code Sign
6. **CPO > Vice President > President** Approve and DocuSign Package (depending on value of amendment)
7. **Ops. Manager** Review and Pin Code Sign Amendment